



เครื่องปรับอากาศ “แคเรียร์”



42CB Series

Fan Coil Unit

Nominal: 400-1,200 CFM



42CB Series



The Compact and Practical 42CB Fan Coil Units

The Carrier 42CB horizontal furred-in Fan Coils are quiet, compact and flexible. Nominal air quantity range from 400 cfm to 1200 cfm. These units are engineered for industrial and commercial applications.

Features

- Ultra-compact design-saves installation space
- High efficiency heat transfer surface
- Super quiet operation
- Low installation and maintenance cost-easy wiring, piping connections
- Installed with direct driven forward curved centrifugal fan and 4-speed high efficient motor
- Minimum power requirement for significant money saving to the owners
- Insulated drain pan
- Factory leak test
- Requires no expensive ductwork
- Ideal for new construction or renovation

Physical Data

Description			Fan Coil Unit							
Model			42CB004		42CB006		42CB008		42CB012	
			2 rows	3 rows	3 rows	4 rows	3 rows	4 rows	3 rows	4 rows
Capacity	Nominal Capacity	BTU/Hr	12,600	14,400	17,500	19,800	22,600	25,500	32,800	37,200
	Nominal Air Flow	CFM	400		600		800		1,200	
Coil	Type		Copper Tubes, Aluminium Fins							
	Coil Face Area	sq. ft.	1.81		1.90		2.31		3.64	
	Row/fpi		2/12	3/12	3/12	4/12	3/12	4/12	3/12	4/12
Connections	Chilled Water	in.	5/8		5/8		5/8		5/8	
	Liquid	in.	3/8	-	3/8	-	3/8	-	3/8	-
	Suction	in.	1/2	-	5/8	-	5/8	-	5/8	-
	Drain (MPT)	in.	3/4		3/4		3/4		3/4	
Fan Motor	Type		Permanent Split Capacitor, 4 speed							
	Power Supply	V/Ph/Hz	220/1/50							
	Hp		1/25		1/20		1/15		1/20	
	No. of Motor		1		1		1		2	
	RLA @		0.38		0.43		0.65		0.43	
Blower Wheel	Type		Centrifugal Forward Curve Blade							
	Diameter		114		144		144		144	
	Width		188		162		188		162	
	No. of Blower		2		2		2		4	
Dimensions	Width	mm.	990		1020		1190		1730	
	Depth	mm.	470		470		470		470	
	Height	mm.	250		250		250		250	
Weights		lb approx.	49		59		64		107	

RLA : Rated Load Amps
MPT : Male Pipe Thread

Unit dimensions

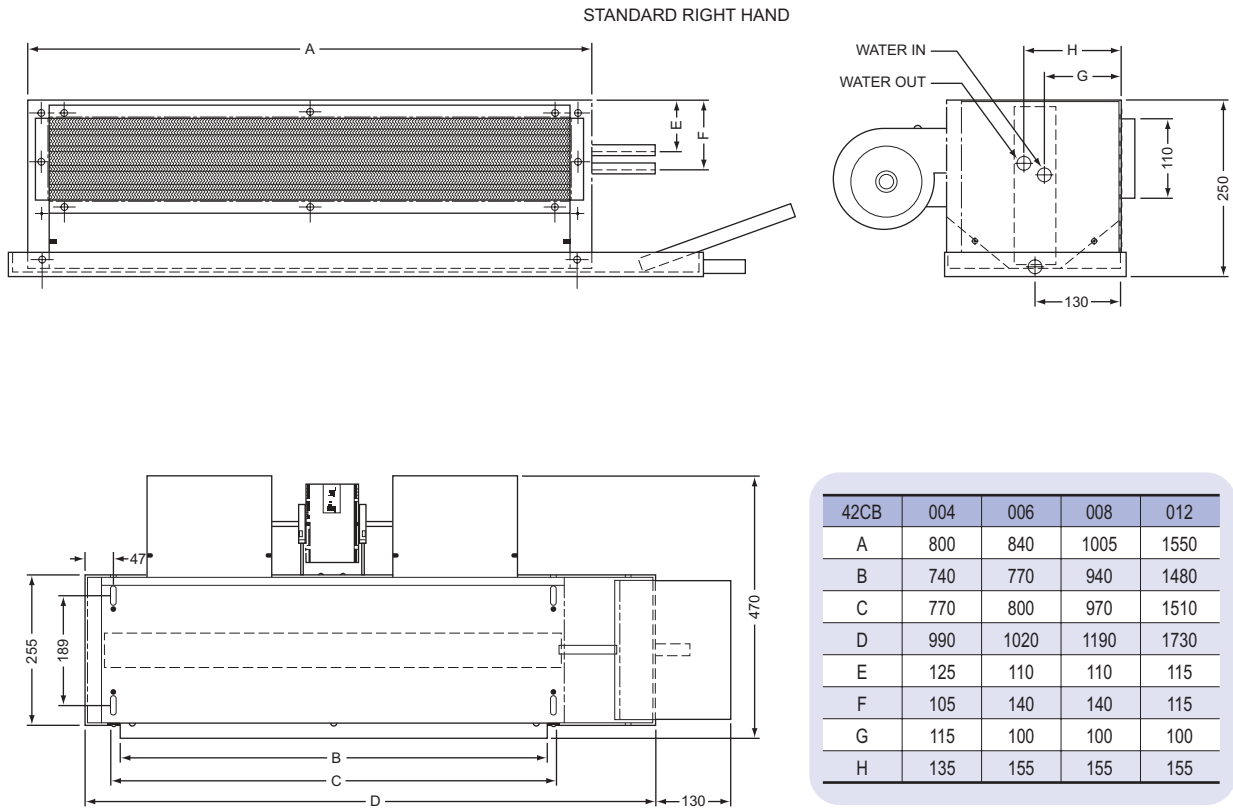

Performance data

Air Delivery (50 Hz)

Model	CFM AT 0.0 ESP			HIGH CFM AT ESP					
	High	Med	Low	0.05	0.10	0.15	0.20	0.25	0.30
42CB004 - 2 rows	630	570	500	560	490	420	345	260	170
42CB006 - 3 rows	870	670	540	800	730	650	570	485	400
42CB008 - 3 rows	1100	790	650	1020	940	850	755	660	550
42CB012 - 3 rows	1500	1050	860	1410	1320	1200	985	840	700
42CB004 - 3 rows	620	560	495	550	480	405	340	250	165
42CB006 - 4 rows	860	660	530	780	710	635	550	470	380
42CB008 - 4 rows	1050	770	640	1000	925	830	740	640	530
42CB012 - 4 rows	1480	970	845	1400	1300	1190	970	830	680

ESP. = External Static Pressure (in. wg)

Notes:

1. Airflow with dry coil conditions.
2. Wet coil cfm is approximately 92% of dry coil cfm.
3. All models without a factory plenum or casing should be operated with a filter and a minimum 0.05 ESP system.

Performance data

2 rows cooling coil for size 004, 3 rows cooling coil for size 006, 008, 012

42°F Entering Water Temperature

Unit	Entering Temp. (°F)		Water Temperature Rise (°F)															
			6		8		10		12		14		16					
	WB	DB	TH	SH	TH	SH	TH	SH	TH	SH	TH	SH	TH	SH	TH	SH		
004			10.5	8.1	9.2	7.7	8.0	7.2	7.1	6.7	6.3	6.2	5.8					
006			14.5	12.1	12.6	11.3	11.0	10.4	10.3	9.7	9.5	8.9	8.5	8.1				
008	61	72	18.8	14.9	16.3	14.0	14.1	13.2	13.2	12.5	12.3	11.6	11.5	10.8				
012			27.2	22.1	23.2	20.2	20.4	19.2	19.0	17.9	17.4	16.4	16.0	15.1				
004			10.5	8.8	9.2	8.3	8.3	7.9	7.9	7.4	7.4	6.9	6.9	6.5				
006			14.5	13.0	12.6	11.9	12.0	11.4	11.2	10.6	10.3	9.7	9.5	8.9				
008	61	74	18.8	16.1	16.3	15.3	15.3	14.4	14.5	13.7	13.7	12.9	12.8	12.1				
012			27.2	24.0	24.1	22.7	22.6	21.3	21.2	20.0	19.7	18.6	18.1	17.0				
004			12.5	8.8	11.3	8.3	10.0	7.9	8.8	7.4	7.6	7.0	6.9	6.5				
006			17.5	13.0	15.7	11.9	13.8	11.4	12.2	10.6	10.4	9.7	9.5	8.9				
008	63	74	22.7	16.1	20.4	15.3	18.1	14.4	15.9	13.7	13.7	12.9	12.8	12.1				
012			33.2	24.0	29.5	22.7	25.5	21.3	21.4	20.0	19.7	18.6	18.1	17.0				
004			12.5	9.6	11.3	9.1	10.0	8.7	8.8	8.2	8.2	7.8	7.7	7.3				
006			17.5	14.1	15.7	13.2	13.8	12.5	12.4	11.7	11.5	10.8	10.5	9.9				
008	63	76	22.7	17.5	20.4	16.6	18.1	15.8	16.0	15.1	15.0	14.2	14.2	13.4				
012			33.2	26.2	29.5	24.7	25.5	23.4	23.3	22.0	22.0	20.8	20.0	19.1				
004			14.9	9.6	13.5	9.1	12.3	8.7	11.1	8.2	9.9	7.8	8.7	7.3				
006			23.0	14.1	18.9	13.2	17.1	12.5	15.4	11.7	13.6	10.8	11.8	9.9				
008	65	76	26.9	17.5	24.4	16.6	22.1	15.8	19.8	15.1	17.6	14.2	15.4	13.4				
012			39.6	26.2	35.4	24.7	31.5	23.4	27.8	22.0	23.7	20.8	20.3	19.1				
004			14.9	10.3	13.5	9.8	12.3	9.4	11.1	8.9	9.9	8.5	8.7	8.0				
006			23.0	15.0	18.9	14.1	17.1	13.4	15.4	12.6	13.6	11.7	11.8	11.0				
008	65	78	26.9	18.9	24.4	18.1	22.1	17.4	19.8	16.5	17.6	15.7	15.9	15.0				
012			39.6	27.9	35.4	26.7	31.5	25.1	27.8	23.8	23.7	22.4	21.8	20.5				
004			17.2	11.0	16.0	10.5	14.6	10.0	13.4	9.7	12.2	9.2	10.9	8.8				
006			23.9	16.0	22.1	15.1	20.2	14.3	18.5	13.6	16.7	12.8	19.3	16.1				
008	67	80	30.8	20.0	28.6	19.3	26.2	18.5	24.0	17.6	21.6	16.8	19.3	26.1				
012			46.3	30.0	42.0	28.7	38.0	27.3	33.8	26.1	30.0	24.6	26.0	23.2				
004			17.2	11.8	16.0	11.3	14.6	10.8	13.4	10.4	12.2	9.9	10.9	9.5				
006			23.9	16.8	22.1	16.2	20.2	15.3	18.5	14.5	16.7	13.8	15.0	13.4				
008	67	82	30.8	21.4	28.6	20.7	26.2	19.8	24.0	19.0	21.6	18.1	19.3	17.5				
012			46.3	32.1	42.0	30.6	38.0	29.2	34.4	27.9	30.0	26.7	26.7	25.2				
004			19.6	11.8	18.4	11.3	17.2	10.8	16.0	10.4	14.6	9.9	13.4	9.5				
006			27.5	16.8	25.6	16.2	23.7	15.3	22.1	14.5	20.1	13.8	18.5	13.0				
008	69	82	35.2	21.4	32.9	20.7	30.6	19.8	28.4	19.0	25.9	18.1	23.6	17.5				
012			52.9	32.1	48.9	30.6	44.7	29.2	40.7	27.9	36.7	26.7	32.4	25.2				
004			19.6	12.4	18.4	12.0	17.2	11.5	16.0	11.2	14.6	10.6	13.4	10.2				
006			27.5	18.1	25.6	17.2	23.7	16.4	22.1	15.7	20.1	14.6	18.5	14.0				
008	69	84	35.2	22.9	32.9	22.1	30.6	21.0	28.4	20.4	25.9	19.7	23.6	18.8				
012			52.9	34.3	48.9	32.8	44.7	31.5	40.7	30.0	36.7	28.7	32.4	27.5				
004			-	-	20.8	12.0	19.6	11.5	18.3	11.2	17.1	10.6	15.8	10.2				
006			31.0	18.1	29.2	17.2	27.2	16.4	25.5	15.7	23.7	14.6	22.0	14.0				
008	71	84	39.7	22.9	37.6	22.1	35.2	21.0	32.9	20.4	30.6	19.7	28.2	18.8				
012			59.7	34.3	55.8	32.8	51.6	31.5	47.7	30.0	43.6	28.7	39.4	27.5				
004			-	-	20.8	12.7	19.6	12.2	18.3	11.8	17.1	11.4	15.8	11.0				
006			31.0	19.1	29.2	18.2	27.1	17.4	25.5	16.7	23.7	15.9	22.0	15.0				
008	71	86	39.7	24.1	37.6	23.4	35.2	22.5	32.9	21.9	30.6	21.0	28.2	20.1				
012			59.7	36.5	55.8	35.0	51.6	33.7	47.7	32.2	43.6	30.9	39.4	29.7				

43°F Entering Water Temperature

Unit	Entering Temp. (°F)		Water Temperature Rise (°F)															
			6		8		10		12		14		16					
	WB	DB	TH	SH	TH	SH	TH	SH	TH	SH	TH	SH	TH	SH	TH	SH		
004			10.0	7.9	8.8	7.4	7.6	7.0	6.8	6.5	6.3	6.1	5.9	5.7				
006			13.8	11.8	12.0	10.9	10.5	10.1	9.8	9.4	9.0	8.7	8.1	7.8				
008	61	72	17.9	14.4	15.5	13.6	13.5	12.8	12.6	12.1	11.7	11.2	10.9	10.5				
012			25.9	21.4	22.1	19.6	19.4	18.7	18.1	17.4	16.5	15.9	15.2	14.6				
004			10.0	8.5	8.8	8.1	7.9	7.6	7.5	7.2	7.0	6.8	6.6	6.3				
006			13.8	12.6	12.0	11.6	11.5	11.0	10.7	10.3	9.8	9.4	9.0	8.7				
008	61	74	17.9	15.6	15.5	14.9	14.6	14.0	13.8	13.3	13.0	12.5	12.2	11.8				
012			25.9	23.3	22.9	22.1	21.5	20.7	20.3	19.4	18.7	18.0	17.2	16.6				
004			11.9	8.5	10.7	8.1	9.6	7.6	8.4	7.2	7.3	6.8	6.6	6.3				
006			16.7	12.6	14.9	11.6	13.1	11.0	11.6	10.3	9.9	9.4	9.0	8.7				
008	63	74	21.6	15.6	19.4	14.9	17.2	14.0	15.1	13.3	13.0	12.5	12.2	11.8				
012			31.6	23.3	28.1	22.1	24.3	20.7	20.4	19.4	18.7	18.0	17.2	16.6				
004			11.9	9.3	10.7	8.9	9.6	8.4	8.4	8.0	7.8	7.5	7.4	7.1				
006			16.7	13.7	14.9	12.9	13.1	12.1	11.8	11.4	10.9	10.5	10.0	9.6				
008	63	76	21.6	17.0	19.4	16.1	17.2	15.4	15.2	14.6	14.3	13.8	13.6	13.0				
012			31.6	25.5	31.1	24.0	24.3	22.7	22.2	21.3	20.9	20.2	19.3	18.6				
004			14.2	9.3	12.9	8.9	11.8	8.4	10.6	8.0	9.4	7.5	8.3	7.1				
006			21.9	13.7	18.0	12.9	16.3	12.1	14.7	11.4	12.9	10.5	11.2	9.6				
008	65	76	25.6	17.0	23.3	16.1	21.1	15.4	18.9	14.6	16.8	13.8	14.7	13.0				
012			37.7	25.5	33.7	24.0	30.0	22.7	26.5	21.3	22.6	20.2	19.3	18.6				
004			14.2	10.0	12.9	9.5	11.8	9.1	10.6	8.6	9.4	8.2	8.3	7.8				
006			21.9	14.6	18.0	13.7	16.3	13.0	14.7	12.2	12.9	11.4	11.2	10.7				
008	65	78	25.6	18.4	23.3	17.6	21.1	16.9	18.9	16.0	16.8	15.3	15.1	14.5				
012			37.7	27.1	33.7	25.9	30.0	24.4	26.5	23.1	22.6	21.7	20.7	19.9				
004			16.4	10.6	15.2	10.2	13.9	9.8	12.8	9.4	11.6	9.0	10.4	8.5				
006			22.7	15.5	21.0	14.7	19.3	13.9	17.6	13.2	15.9	12.4	14.3	11.7				
008	67	80	29.3	19.4	27.2	18.8	24.9	17.9	22.8	17.1	20.6	16.3	18.4	15.6				
012			44.1	29.2	40.0	27.9	36.2	26.5	32.2	25.4	28.6	23.9	24.8	22.5				
004			16.4	11.4	15.2	11.0	13.9	10.5	12.8	10.1	11.6	9.6	10.4	9.2				
006			22.7	16.3	21.0	15.8	19.3	14.9	17.6	14.0	15.9	13.4	14.3	12.6				
008	67	82	29.3	20.8	27.2	20.1	24.9	19.2	22.8	18.5	20.6	17.6	18.4	17.0				
012			44.1	31.2	40.0	29.7	36.2	28.3	32.7	27.1	28.6	25.9	25.5	24.5				
004			18.7	11.4	17.5	11.0	16.4	10.5	15.2	10.1	13.9	9.6	12.8	9.2				
006			26.2	16.3	24.4	15.8	22.6	14.9	21.0	14.0	19.2	13.4	17.6	12.6				
008	69	82	33.5	20.8	31.3	20.1	29.1	19.2	27.0									

Performance data

3 rows cooling coil for size 004, 4 rows cooling coil for size 006, 008, 012

42°F Entering Water Temperature

Unit	Entering Temp. (°F)		Water Temperature Rise (°F)																							
			6				8				10				12				14				16			
	WB	DB	TH	SH	TH	SH	TH	SH	TH	SH	TH	SH	TH	SH	TH	SH	TH	SH	TH	SH	TH	SH				
004			11.9	8.8	10.6	7.8	8.0	7.3	7.3	6.9	6.8	6.4														
006			16.4	12.8	14.5	12.1	12.6	11.5	11.5	10.8	10.8	10.2	10.1	9.5												
008	61	72	21.4	17.0	19.0	16.1	16.4	15.3	15.3	14.1	14.5	13.7	13.5	12.8												
012			30.8	24.6	26.9	23.3	23.2	21.9	22.0	20.8	20.4	19.2	19.1	18.0												
004			11.9	9.7	10.6	9.2	9.4	8.9	8.7	8.2	8.2	7.8	7.7	7.3												
006			16.4	13.3	14.5	13.2	13.3	12.6	12.6	11.9	12.2	11.5	11.5	10.8												
008	61	74	21.4	18.4	19.0	17.5	17.7	16.7	16.8	15.8	15.9	15.0	15.0	14.2												
012			30.8	26.8	28.1	25.6	26.6	24.1	24.3	22.9	22.8	21.5	21.4	20.2												
004			14.3	9.7	13.1	9.2	11.6	8.9	10.4	8.2	9.0	7.8	7.7	7.3												
006			19.6	13.9	18.0	13.2	16.1	12.6	14.3	11.9	12.6	11.5	11.5	10.8												
008	63	74	25.5	18.4	23.2	17.5	20.5	16.7	18.1	15.8	15.9	15.0	15.0	14.2												
012			37.0	26.8	33.0	25.6	28.9	24.1	25.0	22.9	22.8	21.5	21.4	20.2												
004			14.3	10.5	13.1	10.0	11.6	9.6	10.4	9.1	9.2	8.7	8.7	8.2												
006			19.6	15.0	18.0	14.3	16.1	13.7	14.3	13.0	13.1	12.4	12.4	11.7												
008	63	76	25.5	19.7	23.2	18.8	20.5	17.9	18.2	17.2	17.4	16.4	16.3	15.4												
012			37.0	29.0	33.0	27.5	28.9	26.2	26.4	24.9	25.0	23.6	23.6	22.3												
004			16.8	10.5	15.5	10.0	14.2	9.6	12.8	9.1	11.6	8.7	10.2	8.2												
006			23.2	15.0	21.3	14.3	19.2	13.7	17.8	13.0	15.9	12.4	14.0	11.7												
008	65	76	30.1	19.7	27.6	18.8	25.2	17.9	22.6	17.2	20.1	16.4	17.0	15.4												
012			44.3	29.0	40.3	27.5	36.2	26.2	32.1	24.9	28.1	23.6	24.0	22.3												
004			16.8	11.4	15.5	11.0	14.2	10.5	12.8	10.0	11.6	9.6	10.2	9.1												
006			23.2	16.1	21.3	15.5	19.2	14.6	17.8	14.1	15.9	13.5	14.0	12.8												
008	65	78	30.1	21.0	27.6	20.2	25.2	19.3	22.6	18.6	20.1	17.7	17.9	16.9												
012			44.3	31.0	40.3	29.7	36.2	28.3	31.1	27.0	28.1	25.7	25.8	24.4												
004			26.7	17.0	24.8	16.3	22.9	15.8	21.3	15.2	19.4	14.6	17.5	13.9												
006			34.6	22.3	32.0	21.3	29.5	20.5	27.0	19.8	24.4	18.9	21.9	18.0												
012			51.2	33.0	47.1	31.7	43.1	30.3	39.1	29.0	35.2	27.8	31.0	26.4												
004			26.7	18.1	26.8	17.2	22.9	15.5	21.1	14.6	18.0	11.2	12.8	10.7												
006			34.6	23.5	32.0	22.7	29.5	22.1	27.0	21.1	24.4	20.2	21.9	19.3												
012			51.2	35.3	47.1	33.9	43.1	32.6	39.1	31.3	35.2	29.9	31.0	28.6												
004			30.5	18.1	20.9	12.6	19.5	12.1	18.3	11.6	16.9	11.2	15.6	10.7												
006			38.5	23.5	37.0	22.7	34.5	22.1	30.9	21.1	29.5	20.2	27.1	21.3												
012			58.5	35.3	54.4	33.9	50.2	32.6	46.2	31.3	42.3	29.9	38.2	29.6												
004			30.5	19.3	28.6	18.7	26.9	18.0	25.0	17.3	23.2	16.8	21.4	16.1												
006			39.7	25.1	37.0	24.0	34.5	23.5	30.9	22.5	29.5	21.6	27.1	20.8												
012			58.5	37.3	54.4	36.0	50.2	34.6	46.2	33.3	42.3	32.0	38.2	30.7												
004			34.5	19.3	32.7	18.7	30.9	18.0	29.0	17.3	27.2	16.8	25.4	16.1												
006			42.3	24.3	39.6	23.5	37.0	22.5	34.6	21.6	32.0	21.6	30.0	20.8												
012			66.0	37.3	61.8	36.0	57.9	34.6	53.8	33.3	49.8	32.0	45.7	30.7												
004			34.5	20.4	32.7	19.8	30.9	19.1	29.0	18.5	27.2	17.9	25.4	17.2												
006			42.3	25.7	39.6	24.6	37.0	23.8	34.6	22.9	32.0	22.0	30.0	22.2												
012			66.0	39.3	61.8	38.1	57.9	36.8	53.8	35.5	49.8	34.2	45.7	32.8												

43°F Entering Water Temperature

Unit	Entering Temp. (°F)		Water Temperature Rise (°F)																							
			6				8				10				12				14				16			
	WB	DB	TH	SH	TH	SH	TH	SH	TH	SH	TH	SH	TH	SH	TH	SH	TH	SH	TH	SH	TH	SH				
004			11.3	8.5	10.1	8.1	8.8	7.5	7.6	7.1	6.9	6.7	6.5	6.2												
006			15.6	12.4	13.8	11.8	12.0	11.1	10.9	10.5	10.2	9.9	9.6	9.2												
008	61	72	20.4	16.6	18.1	15.6	15.7	14.9	14.6	14.0	13.8	13.3	12.9	12.4												
012			29.3	23.9	25.6	22.6	22.1	21.2	20.9	20.2	19.4	18.7	18.2	17.5												
004			11.3	9.4	10.1	9.0	9.0	8.6	8.3	8.0	7.8	7.5	7.4	7.1												
006			15.6	13.5	13.8	12.9	12.7	12.2	12.0	11.6	11.6	11.1	10.9	10.5												
008	61	74	20.4	17.8	18.1	17.0	16.9	16.2	16.0	15.4	15.1	14.5	14.3	13.8												
012			29.3	26.0	25.8	24.8	24.4	23.4	23.2	22.3	21.7	20.9	20.4	19.6												
004			13.6	9.4	12.4	9.0	11.1	8.6	9.9	8.0	8.5	7.5	7.4	7.1												
006			18.7	13.5	17.1	12.9	15.4	12.2	13.6	11.6	12.0	11.1	10.9	10.5												
008	63	74	24.3	17.8	22.1	17.0	19.5	16.2	17.2	15.4	15.1	14.5	14.3	13.8												
012			35.3	26.0	31.4	24.8	27.6	23.4	23.8	22.3	21.7	20.9	20.4	19.6												
004			13.6	10.2	12.4	9.8	11.1	9.3	9.9	8.9	8.8	8.4	8.3	8.0												
006			18.7	14.6	17.1	13.9	15.4	13.3	13.6	12.6	12.5	12.0	11.8	11.4												
008	63	76	24.3	19.1	22.1	18.2	19.5	17.4	17.3	16.7	16.5	15.9	15.5	15.0												
012			35.3	28.1	31.4	26.7	27.6	25.5	25.1	24.2	23.8	22.9	22.5	21.6												
004			16.0	10.2	14.7	9.8	13.5	9.3	12.2	9.8	11.1	8.4	9.7	8.0												
006			22.0	14.6	20.3	13.9	18.3	13.3	16.9	12.6	15.1	12.0	13.4	11.4												
008	65	76	28.7	19.1	26.2	18.2	20.4	17.4	21.5	16.2	19.2	15.9	16.9	15.0												
012			42.2	28.1	38.4	26.7	34.5	25.5	30.5	24.2	26.8	22.9	22.8	21.6												
004			16.0	11.1	14.7	10.6	13.5	10.2	12.2	9.8	11.1	9.3	9.7	8.9												
006			22.0	15.6	20.3	15.0	18.3	14.1	16.9	13.7	15.1	13.1	13.4	12.4												
008	65	78	28.7	20.4	26.2	19.6	24.0	18.8	21.5	18.0	19.2	17.2	17.1	16.4												
012			42.2	30.1	38.4	28.9	34.5	27.5	30.5	26.2	28.8	24.9	24.6	23.7												
004			25.4	16.5	23.6	15.9	21.8	15.3	20.3	14.8	18.5	14.1	16.7	13.5												
006			33.0	21.6	30.4	20.7	28.1	19.9	25.7	19.2	23.3	18.4	20.8	17.5												
012			48.7	32.0	44.9	30.8	41.0	29.4	37.3	28.1	33.5	26.9	29.5	25.7												
004			25.4	17.6	23.6	16.9	21.8	16.3	20.3	15.6	18.5	15.0	16.7	14.4												

Performance data

Chilled Water Coil Pressure Drop (Δp) (FT of Water)

Cv Factor	Water Flow Rate (GPM)																									
	0.5	1.0	1.5	2.0	2.5	3.0	3.5	4.0	4.5	5.0	5.5	6.0	6.5	7.0	7.5	8.0	8.5	9.0	9.5	10.0	10.5	11.0	11.5	12.0	13.0	14.0
0.8	0.9	3.6	8.1	14.4	22.5	32.4	-	-	-	-	-	-	-	-	-	-	-	-	-	-	-	-	-	-	-	-
0.9	0.7	2.8	6.4	11.4	17.8	25.6	34.9	-	-	-	-	-	-	-	-	-	-	-	-	-	-	-	-	-	-	-
1.0	0.5	2.3	5.2	9.2	14.4	20.7	28.2	36.9	-	-	-	-	-	-	-	-	-	-	-	-	-	-	-	-	-	-
1.1	0.4	1.9	4.2	7.6	11.9	17.1	23.3	30.5	-	-	-	-	-	-	-	-	-	-	-	-	-	-	-	-	-	-
1.2	-	1.6	3.6	6.4	10.0	14.4	19.6	25.6	32.4	-	-	-	-	-	-	-	-	-	-	-	-	-	-	-	-	-
1.3	-	1.3	3.0	5.4	8.5	12.3	16.7	21.8	27.6	34.1	-	-	-	-	-	-	-	-	-	-	-	-	-	-	-	-
1.4	-	1.1	2.6	4.7	7.3	10.6	14.4	18.8	23.8	29.4	-	-	-	-	-	-	-	-	-	-	-	-	-	-	-	-
1.5	-	1.0	2.3	4.1	6.4	9.2	12.5	16.4	20.7	25.6	31.0	-	-	-	-	-	-	-	-	-	-	-	-	-	-	-
1.6	-	0.9	2.0	3.6	5.6	8.1	11.0	14.4	18.2	22.5	27.2	32.4	-	-	-	-	-	-	-	-	-	-	-	-	-	-
1.7	-	0.8	1.8	3.2	4.9	7.1	9.7	12.7	16.1	19.9	24.1	28.7	33.7	-	-	-	-	-	-	-	-	-	-	-	-	-
1.8	-	0.7	1.6	2.8	4.4	6.4	8.7	11.4	14.4	17.8	21.5	25.6	30.1	-	-	-	-	-	-	-	-	-	-	-	-	-
1.9	-	0.6	1.4	2.5	4.0	5.7	7.8	10.2	12.9	15.9	19.3	23.0	27.0	31.3	-	-	-	-	-	-	-	-	-	-	-	-
2.0	-	0.5	1.3	2.3	3.6	5.2	7.0	9.2	11.6	14.4	17.4	20.7	24.4	28.2	32.4	-	-	-	-	-	-	-	-	-	-	-
2.1	-	0.5	1.1	2.0	3.2	4.7	6.4	8.3	10.6	13.0	15.8	18.8	22.1	25.6	29.4	33.5	-	-	-	-	-	-	-	-	-	-
2.2	-	0.4	1.0	1.9	2.9	4.2	5.8	7.6	9.6	11.9	14.4	17.1	20.1	23.3	26.8	30.5	-	-	-	-	-	-	-	-	-	-
2.3	-	-	0.9	1.7	2.7	3.9	5.3	6.9	8.8	10.9	13.2	15.7	18.4	21.3	24.5	27.9	31.5	-	-	-	-	-	-	-	-	-
2.4	-	-	0.9	1.6	2.5	3.7	4.9	6.4	8.1	10.0	12.1	14.4	16.9	19.6	22.5	25.6	28.9	32.4	-	-	-	-	-	-	-	-
2.5	-	-	0.8	1.4	2.3	3.3	4.5	5.9	7.4	9.2	11.1	13.3	15.6	18.1	20.7	23.6	26.7	29.9	33.3	-	-	-	-	-	-	-
2.6	-	-	0.7	1.3	2.1	3.0	4.1	5.4	6.9	8.5	10.3	12.3	14.4	16.7	19.2	21.8	24.6	27.6	30.8	-	-	-	-	-	-	-
2.7	-	-	0.7	1.2	1.9	2.8	3.8	5.0	6.4	7.9	9.5	11.4	13.3	15.5	17.8	20.2	22.8	25.6	28.5	31.6	-	-	-	-	-	-
2.8	-	-	0.6	1.1	1.8	2.6	3.6	4.7	5.9	7.3	8.9	10.6	12.4	14.4	16.5	18.8	21.2	23.8	26.5	29.4	32.4	-	-	-	-	-
2.9	-	-	0.6	1.1	1.7	2.4	3.3	4.3	5.5	6.8	8.3	9.8	11.6	13.4	15.4	17.5	19.8	22.2	24.7	27.4	30.2	-	-	-	-	-
3.0	-	-	0.5	1.0	1.6	2.3	3.1	4.1	5.2	6.4	7.7	9.2	10.8	12.5	14.4	16.4	18.5	20.7	23.1	25.6	28.2	31.0	-	-	-	-
3.2	-	-	0.5	0.9	1.4	2.0	2.7	3.6	4.5	5.6	6.8	8.1	9.5	11.0	12.6	14.4	16.3	18.2	20.3	22.5	24.8	27.2	29.8	-	-	-
3.4	-	-	-	0.8	1.2	1.8	2.4	3.2	4.0	4.9	6.0	7.1	8.4	9.7	11.2	12.7	14.4	16.1	18.0	19.9	22.0	24.1	26.4	28.7	-	-
3.6	-	-	-	0.7	1.1	1.6	2.1	2.8	3.6	4.4	5.3	6.4	7.5	8.7	10.0	11.4	12.8	14.4	16.0	17.8	19.6	21.5	23.5	25.6	30.1	-
3.8	-	-	-	0.6	1.0	1.4	1.9	2.5	3.2	4.0	4.8	5.7	6.7	7.8	9.0	10.2	11.5	12.9	14.4	15.9	17.6	19.3	21.1	23.0	27.0	31.3
4.0	-	-	-	0.5	0.9	1.3	1.7	2.3	2.9	3.6	4.3	5.2	6.1	7.0	8.1	9.2	10.4	11.6	13.0	14.4	15.9	17.4	19.0	20.7	24.4	28.2

Note: Interpolation is permitted; do not extrapolate. To calculate pressure drop for Cv factors and flow rates not shown in the table, use the following formula

$$\Delta P = \frac{(\text{GPM})^2}{(\text{Cv})^2} \times 2.31$$

Chilled Water Coil Cv Factors

Unit Size	2-Row	3-Row	4-Row
42CB004	1.2	0.9	-
42CB006	-	2.4	2.0
42CB008	-	2.2	1.9
42CB012	-	3.2	3.0

Direct expansion cooling capacities, MBTUH

R-22 Only.

Unit Size	Suction Temp. °F	Entering Air Temperature db, wb (°F)																							
		72.61		74.61		76.63		76.65		78.65		80.67		82.67		82.69		84.69		84.71		86.71			
		TH	SH	TH	SH	TH	SH	TH	SH	TH	SH	TH	SH	TH	SH	TH	SH	TH	SH	TH	SH	TH	SH		
42CB004	30	17.5	11.7	17.5	12.4	19.2	12.4	19.2	12.4	12.9	12.9	21.2	12.9	12.9	13.5	23.1	14.1	14.7	14.7	25.2	14.7	14.7	27.3	15.2	16.0
	35	14.9	10.3	14.9	10.8	16.9	10.8	16.9	11.5	11.5	18.4	11.5	11.5	12.1	20.4	12.8	13.3	13.3	22.5	13.3	13.3	24.5	13.9	14.6	
	40	11.9	8.8	11.9	9.4	13.7	9.4	13.7	10.1	10.1	15.5	10.1	10.1	10.7	17.5	11.3	11.9	11.9	19.4	11.9	11.9	21.5	12.6	13.2	
	45	8.5	7.3	8.5	7.9	10.4	7.9	10.4	8.5	8.5	12.1	8.5	8.5	9.1	14.1	9.8	10.5	10.5	16.1	10.5	10.5	18.1	11.1	11.6	
	50	6.3	5.8	6.3	6.0	6.6	6.6	6.6	6.3	6.3	8.7	6.3	6.3	7.4	10.6	8.4	9.0	9.0	12.6	9.0	9.0	14.7	9.7	10.3	
42CB006	30	24.9	17.2	24.9	18.1	27.3	18.1	27.3	18.9	18.9	29.5	18.5	18.5	19.7	33.6	20.7	21.7	21.7	35.4	21.7	21.7	39.2	22.5	23.6	
	35	21.0	14.9	21.0	15.9	23.5	15.9	23.5	16.8	16.8	25.7	16.5	16.5	17.6	29.7	18.5	19.5	19.5	31.3	19.5	19.5	34.9	20.4	21.3	
	40	16.9	12.8	16.9	13.7	19.4	13.7	19.4	14.6	14.6	21.4	14.2	14.2	15.5	25.3	16.3	17.3	17.3	27.2	17.3	17.3	30.6	18.3	19.0	
	45	12.3	10.6	12.3	11.5	14.7	11.5	14.7	12.4	12.4	17.0	12.1	12.1	13.3	20.6	14.2	15.0	15.0	22.5	15.0	15.0	25.9	16.1	17.0	
	50	10.3	8.7	10.3	9.3	10.5	9.3	10.5	10.1	10.1	12.2	9.9	9.9	11.0	15.5	11.9	12.7	12.7	17.6	12.7	12.7	20.8	13.9	14.8	
42CB008	30	31.3	22.2	31.3	22.2	34.5	23.3	34.5	24.4	24.4	37.7	23.9	23.9	25.6	42.6	26.7	27.9	27.9	45.1	27.9	27.9	50.5	29.2	30.5	
	35	26.8	19.2	26.8	20.5	29.7	20.5	29.7	21.4	21.4	32.6	20.9	20.9	22.6	37.7	23.7	24.8	24.8	39.6	24.8	24.8	44.3	26.2	27.2	
	40	21.7	16.5	21.7	17.7	24.6	17.7	24.6	18.7	18.7	27.3	18.2	18.2	19.7	32.1	20.8	22.1	22.1	34.6	22.1	22.1	38.8	23.4	24.5	
	45	16.1	13.7	16.1	14.7	19.0	14.7	19.0	16.0	16.0	21.8	15.7	15.7	17.0	26.2	18.1	19.4	19.4	28.8	19.4	19.4	32.9	20.4	21.7	
	50	12.1	11.0	12.1	11.8	12.9	11.8	12.9	12.9	12.9	15.7	12.6	12.6	14.2	19.9	15.4	16.5	16.5	22.5	16.5	16.5	26.6	17.8	18.9	
42CB012	30	47.4	32.9	47.4	34.5	52.1	34.5	52.1	36.1	36.1	56.3	35.3	35.3	37.9	64.2	39.4	41.3	41.3	67.4	41.3	41.3	75.1	43.1	45.0	
	35	41.5	28.8	41.5	30.6	46.5	30.6	46.5	32.2	32.2	50.8	31.5	31.5	33.9	58.6	35.5	37.2	37.2	62.1	37.2	37.2	69.5	39.4	41.0	
	40	33.4	24.6	33.4	26.4	38.2	26.4	38.2	28.0	28.0	42.6	27.4	27.4	29.7	50.1	31.5	33.1	33.1	53.8	33.1	33.1	60.9	35.1	36.9	
	45	24.7	20.4	24.7	21.9	29.4	21.9	29.4	23.8	23.8	33.8	23.3	23.3	25.5	40.6	27.2	28.9	28.9	44.9	28.9	28.9	51.8	31.0	32.6	
	50	18.9	15.7	18.9	17.7	19.4	17.7	19.4	19.4	19.4	24.4	19.0	19.0	21.2	30.7	23.0	24.2	24.2	34.9	24.2	24.2	41.4	26.8	28.8	

SH : Sensible Heat Capacity
TH : Total Heat Capacity

Metric conversion chart

Metric Tech	x	=	English Unit	x	=	SI Unit
Area						
cm ²				100		mm ²
cm ²	0.1550		in. ²	645.2		mm ²
m ²				1.0		m ²
m ²	10.76		ft ²	0.09290		m ²
Length						
μm				1.0		μm
μm	39.37		micro-inch	0.0254		μm
mm				1.0		mm
mm	0.03937		in.	25.4		mm
mm	0.003281		ft	304.8		mm
m				1.0		m
m	3.281		ft	0.3048		m
m	1.094		yd	0.9144		m
Mass						
g				1.0		g
g	0.03527		oz	28.35		g
kg				1.0		kg
kg	2.205		lb	0.4536		kg
tonne, Mg				1.0		tonne, Mg
tonne, Mg	1.102		U.S. ton (2000 lb)	0.9072		tonne, Mg
Power						
kcal/h				1.163		W
kcal/h	3.968		Btu/h	0.2931		W
Hp metric				0.7355		kW
Hp metric	0.9863		HP (550 $\frac{ft \cdot lb}{s}$)	0.7457		kW
Mcal/h				1.163		kW
Mcal/h	0.3307		Ton refr.	3.517		kW
Pressure						
mm w.g. 4°C				9.806		Pa
mm w.g. 4°C	0.03937		in H ₂ O 39.2°F	249.1		Pa
mm Hg 0°C				0.1333		kPa
mm Hg 0°C	0.03937		in Hg 32°F	3.386		kPa
kgf/cm ²				98.07		kPa
kgf/cm ²	14.22		psi	6.895		kPa
mH ₂ O	3.281		ft H ₂ O	2.989		kPa

Metric Tech	x	=	English Unit	x	=	SI Unit
Temperature Interval						
°C				1.0		K
°C	1.8		°F	0.5556		°C
Velocity						
m/s				1.0		m/s
m/s	3.281		ft/s	0.3048		m/s
m/s	196.9		ft/min	0.00508		m/s
Volume						
mm ³				1.0 x 10 ⁻⁶		L
mm ³	6.102 x 10 ⁻⁵		in. ³	0.01639		L
L				1.0		L
L	0.03531		ft ³	28.32		L
m ³				1.0		m ³
m ³	1.308		yd ³	0.7646		m ³
L	0.2642		U.S. gal	3.785		L
L	2.113		U.S. pint	0.4732		L
mL, cm ³				1.0		mL
mL, cm ³	0.03381		U.S. oz	29.57		mL
Volume/Time						
m ³ /h				0.2778		L/s
m ³ /h	0.5886		ft ³ /min	0.4719		L/s
m ³ /h	4.403		U.S. gal/min	0.06309		L/s
L/h				2.778 x 10 ⁻⁴		L/s
L/h	4.403 x 10 ⁻³		U.S. gal/min	0.06309		L/s
(m ³ /h)/ (1000 kcal/h)	1.780		cfm/ton	0.1342		L/s kw

Metric Tech	Conversion Factor	=	English Unit	Conversion Factor	=	SI Unit
Temperature						
°C				°C + 273.15		K
°C	(°C x 1.8) + 32		°F	(°F - 32) ÷ 1.8		°C

Prefixes

M	MEGA	- 10 ⁶
k	KILO	- 10 ³
d	DECI	- 10 ⁻¹
c	CENTI	- 10 ⁻²
m	MILLI	- 10 ⁻³
μ	MICRO	- 10 ⁻⁶

Legend

m	METER	K	KELVIN
cal	CALORIE	W	WATT
kg	KILOGRAM (mass)	Pa	PASCAL
kgf	KILOGRAM - FORCE	J	JOULE
L	LITER	N	NEWTON
°C	DEGRESS CELSIUS	h	HOUR

Units

cP	CENTIPOISE	mm Hg	MILLIMETERS MERCURY
cSt	CENTISTOKE	tonne	= 1000 kg
HP metric	= (PS, CV, ch) METRIC HORSEPOWER	kcal	= fg FRIGORIE
mm w.g.	MILLIMETERS WATER GAUGE	bar	= 100 kPa

บริษัท แคนเรียร์ (ประเทศไทย) จำกัด
 ชั้น 14-15 อาคารเนชั่น ทาวเวอร์
 46/63-74 ถ.บางนา-ตราด กม. 4.5
 บางนา กรุงเทพฯ 10260
 โทร. 0-2751-4777 แฟกซ์: 0-2751-4778

Carrier (Thailand) Ltd.
 14-15th Fl., Nation Tower,
 46/63-74 Bangna-Trad Road Km. 4.5, Bangna,
 Bangkok 10260 Thailand
 Tel.: 0-2751-4777 Fax: 0-2751-4778



YOUR CARRIER MAN :